

## OFFICE PAPER RECYCLING BIN : FOR MAXIMUM RESOURCE RECOVERY



EASY HANDLING  
DURABLE CONSTRUCTION  
ENVIRONMENTALLY-  
RESPONSIBLE

### Removable waste holder

- Fits neatly in place
- Simplifies daily waste disposal
- Optional bin liner easily fitted
- Ensures high quality paper recovery through lower contamination



### Handles

- Moulded in handles for comfort
- Easy to carry for convenient use



### Benefits

- Compact shape fits neatly under desk
- Provides for source separation of high quality paper
- Eliminates the need for 2 or more bins
- Waste holder reduces contamination
- Flat storage of paper allows greater recovery volume



# OFFICE PAPER RECYCLING

## Material

### OUTER BIN

#### ■ Polymer components:

- Injection moulded from specially designed PP
- Resistant to decay, frost, heat and chemicals
- Special UV stabilisers provide excellent ageing characteristics

#### ■ Long service life:

- High quality materials
- Most advanced manufacturing processes

#### ■ Recycling:

- Minimum of 30% recycled content used in manufacturing
- All container parts are 100% recyclable

### INNER BIN

#### ■ Polymer components:

- Injection moulded from specially designed HDPE
- Resistant to decay, frost, heat and chemicals
- Special UV stabilisers provide excellent ageing characteristics

#### ■ Long service life:

- High quality materials
- Most advanced manufacturing processes

#### ■ Recycling:

- All container parts are 100% recyclable

## Advantages

#### ■ Easy handling:

- Practical handle for effortless emptying
- Light weight for easy movement
- Space saving for convenient use
- Eliminates the need for 2 or more bins
- Inner bin slots in place and easily lifts out for hygienic emptying
- Reduces contamination of recyclables
- Maximises paper recycling
- Waterproof, easily cleaned

## Imprints and markings

- Individual markings with imprints or adhesive labels are available on request



SULO MGB Australia Pty Ltd  
123 Wisemans Ferry Road  
Somersby NSW 2250

#### Australia

Tel: +61 (0) 2 - 4348 8188  
Fax: +61 (0) 2 - 4348 8128  
Internet: [www.sulo.com.au](http://www.sulo.com.au)  
E-mail: [info@sulo.com.au](mailto:info@sulo.com.au)

SULO – Queensland Office  
11 Argon Street  
Sumner Park QLD 4074

#### Australia

Tel: +61 (0) 7 - 3725 5000  
Fax: +61 (0) 7 - 3725 5099

## Dimensions - Weights - Standards

- Nominal volume: Outer bin 13.5 litres
- Nominal volume: Inner bin 8.5 litres
- Net weight: 1.3kg
- Permitted total weight: 7.5 kg

measurements to be used as a guide only - variations will occur

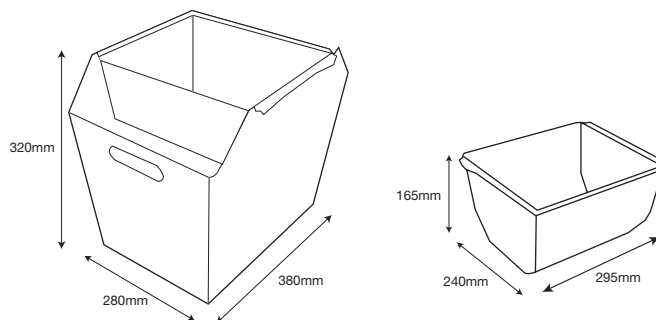

nominal dimensions

## Colours

- Special colours including corporate colours for both outer and inner bins are available on request\*
- Standard colours:  
Outer bin: Black  
Inner bin: Red, Black, Orange, Burgundy

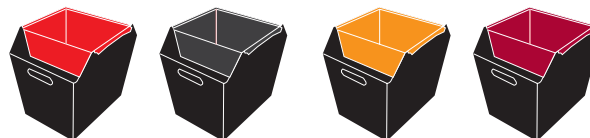

## Additional products

- Organic waste containers
- Locks and slots on 2 and 4 wheel mobile garbage bins for secure document collection

SULO – Victorian Office  
1950 Hume Hwy  
Campbellfield VIC 3061

#### Australia

Tel: +61 (0) 3 - 9357 7320  
Fax: +61 (0) 3 - 9357 7340

SULO - New Zealand  
PO Box 58 962  
Greenmount, Manukau City 2141

#### New Zealand

Tel: +64 9 273 6870  
Fax: +64 9 273 8483