

660 LITRE CONTAINER: A FRESH LOOK AT AN OLD FAVOURITE



**EASY HANDLING
MAXIMUM SAFETY
ATTRACTIVE DESIGN**

Easy handling

- Easy grip handles on all sides
- For easy filling
- For safe manoeuvring
- Compatible with identification and weighing systems



Reinforced base

- Ensures stability even when fully loaded
- Very stable wheel assemblies
- Reinforced base, front and rear panels for greater stability



Maximum safety

- User friendly
- Foot pedals on the front wheels lock the bin in position
- Directional locks are ideal for use with towing equipment



660 litre Container

Material

- **Polymer components:**
 - Injection moulded from specially designed HDPE
 - Resistant to decay, frost, heat and chemicals
 - Special UV-stabilisers provide excellent ageing characteristics
- **Corrosion resistant steel components**
- **Noise reduction:**
 - Quiet-running tyres
- **Long service life:**
 - High quality materials
 - Most advanced manufacturing processes
 - Withstands exposure to high mechanical stress levels
- **Recycling:**
 - All container parts are recyclable

Design

ADVANTAGES FOR THE USER:

- Easy handling, even with heavy loads
- Easy grip handles on all sides
- Stable and light weight lid
- User-friendly design
- Various wheel assembly configurations for different applications
- Water drainage plug as standard†
- Compatible with identification and weighing systems
- Suitable for all lifting equipment in accordance with EN 840
- Easy to clean due to smooth and rounded internal corners
- Rounded lid profile for improved rainwater dispersal
- Fitted as standard with chip nest in accordance with RAL GZ 951/1
- Reinforced base, front and rear panels for greater stability

Accessories

- For accessories and special design variations such as lid apertures, locks and towing brackets, please refer to the separate accessories sheet for 4-wheeled containers

SULO®

SULO MGB Australia Pty Ltd
123 Wisemans Ferry Road
Somersby NSW 2250

Australia

Tel: +61 (0) 2 - 4348 8188
Fax: +61 (0) 2 - 4348 8128
Internet: www.sulo.com.au
E-mail: info@sulo.com.au

SULO – Queensland Office
11 Argon Street
Sumner Park QLD 4074

Australia

Tel: +61 (0) 7 - 3725 5000
Fax: +61 (0) 7 - 3725 5099

Quality

- Certified according to DIN EN 840 and RAL GZ 951/1
- Constant quality control through manufacturers laboratory as well as independent institutes

Dimensions - Weights - Standards

■ Nominal volume:	660 litres
■ Net weight:	43 kg
■ Max. load:	265 kg
■ Permitted total weight:	310 kg

Measurements to be used as a guide only - variations will occur

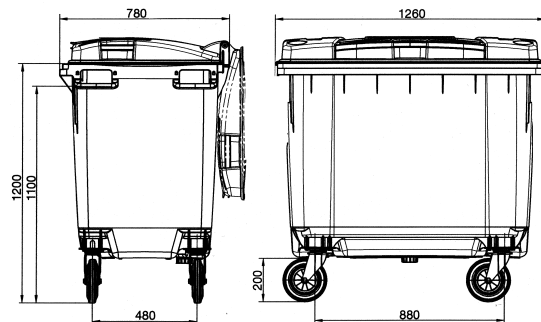

Note: Certification and Quality Marks depicted in this brochure are registered to SULO Umwelttechnik GmbH & Co. KG

Colours

- Standard colours: green, blue, yellow
- Special colours are available on request
- All additives are cadmium free and environmentally friendly



Imprints and markings

- Manufacturer, year of manufacture, material
- Nominal volume, max. permitted total weight
- "No hot ashes" symbol
- EN 840, RAL markings
- Individual markings with imprints, hot-foil printing or adhesive labels available on request*

SULO – Victorian Office
1950 Hume Hwy
Campbellfield VIC 3061

Australia

Tel: +61 (0) 3 - 9357 7320
Fax: +61 (0) 3 - 9357 7340

SULO - New Zealand
PO Box 58 962

Greenmount, Manukau City 2141

New Zealand

Tel: +64 9 273 6870
Fax: +64 9 273 8483