

## 1100 LITRE FLAT LID CONTAINER: THE BEST IN ITS CLASS



**UNIQUE DESIGN  
EASY HANDLING  
IMPROVED SAFETY**

### Improved handling

- Easy grip handles on all sides
- Optimum manoeuvrability
- Compatible with identification and weighing systems



### Increased safety

- Foot pedals on the front wheels lock the bin in position
- Increased stability
- Directional locks are ideal for use with towing equipment



### Benefits

- Accessories easily fitted
- Complies to EN840 standard
- Safe and easy handling



# 1 100 Litre Flat Lid Container

## Material

- **Polymer components:**
  - Injection moulded from specially designed HDPE
  - Resistant to decay, frost, heat and chemicals
  - Special UV-stabilisers provide excellent ageing characteristics
- **Corrosion resistant steel components**
- **Noise reduction:**
  - Wheel assemblies with solid rubber tyres
- **Long service life:**
  - High quality materials
  - Excellent manufacturing processes
  - Withstands exposure to high mechanical stress levels
- **Recycling:**
  - All container parts are recyclable

## Design

- Easy handling through the use of ergonomic handles
- Versatile, with a comprehensive accessories range
- In accordance with the safety requirements of EN-840
- Easy grip handles on all sides
- Safe, easy handling, even with heavy loads
- Various wheel assembly configurations for different applications
- Improved water drainage as a result of rounded lids
- Water drainage plug as standard\*
- Compatible with identification and weighing systems
- Reinforced base, front and rear panels for greater stability
- Fitted as standard with chip nest in accordance with RAL GZ 951/1
- Easy to clean due to smooth surfaces and rounded internal corners

## Accessories

- For accessories and special design variations such as lid apertures, locks and towing brackets, please refer to the separate accessories sheet for 4-wheeled containers

## Quality

- Certified according to DIN EN 840 and RAL GZ 951/1
- Constant quality control through manufacturers laboratory as well as independent institutes

## Dimensions - Weights - Standards

- Nominal volume: 1100 litres
- Net weight: approx. 65 kg
- Max. load: 440 kg
- Permitted total weight: 510 kg

Measurements to be used as a guide only -variations will occur

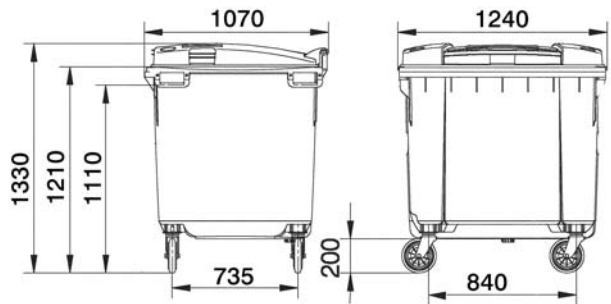

Note: Certification and Quality Marks depicted in this brochure are registered to SULO Umwelttechnik GmbH & Co. KG

## Colours

- Standard colours: green, blue, yellow
- Special colours are available on request\*
- All additives are cadmium free and environmentally friendly



## Imprints and markings

- Manufacturer, year of manufacture, material
- Nominal volume, max. permitted total weight
- EN 840, RAL markings
- Individual markings with imprints, hot-foil printing or adhesive labels available on request \*

# SULO®

SULO MGB Australia Pty Ltd  
123 Wisemans Ferry Road  
Somersby NSW 2250

### Australia

Tel: +61 (0) 2 - 4348 8188  
Fax: +61 (0) 2 - 4348 8128  
Internet: www.sulo.com.au  
E-mail: info@sulo.com.au

SULO – Queensland Office  
11 Argon Street  
Sumner Park QLD 4074

### Australia

Tel: +61 (0) 7 - 3725 5000  
Fax: +61 (0) 7 - 3725 5099

SULO – Victorian Office  
1950 Hume Hwy  
Campbellfield VIC 3061

### Australia

Tel: +61 (0) 3 - 9357 7320  
Fax: +61 (0) 3 - 9357 7340

SULO - New Zealand  
PO Box 58 962  
Greenmount, Manukau City 2141

### New Zealand

Tel: +64 9 273 6870  
Fax: +64 9 273 8483