

1100 LITRE DOMED LID CONTAINER: SECOND GENERATION, FIRST CLASS



**UNIQUE DESIGN
EASY HANDLING
IMPROVED SAFETY**

Safety Handles

- Easy grip handles on all sides
- Optimum manoeuvrability
- Compatible with identification and weighing systems



Safety Trunnion

- Increased stability
- Increased safety when lifting



Safety Lid

- High degree of safety with integrated child safety device
- Closes automatically after emptying



1 100 Litre Domed Lid Container

Material

- **Polymer components:**
 - Injection moulded from specially designed HDPE
 - Resistant to decay, frost, heat and chemicals
 - Special UV-stabilisers provide excellent ageing characteristics
- **Corrosion resistant steel components**
- **Noise reduction:**
 - Wheel assemblies with solid rubber tyres
- **Long service life:**
 - High quality materials
 - Excellent manufacturing processes
 - Withstands exposure to high mechanical stress levels
- **Recycling:**
 - All container parts are recyclable

Design

- Easy to use lid, lockable, with adjustable spring support system
- High degree of safety - integrated child safety device prevents accidental closing of lid
- Versatile, with a comprehensive accessories range
- Easy grip handles on all sides
- Safe, easy handling, even with heavy loads
- Wide lifting trunnions for improved safety during lifting, even with awkward loads
- Various wheel assembly configurations for different applications
- Water drainage plug as standard†
- Compatible with identification and weighing systems
- Domed lid with unique opening mechanism reduces wind problems during emptying
- Easy to clean due to smooth surfaces and rounded internal surfaces
- Reinforced base, front and rear panels for greater stability

Accessories

- For accessories and special design variations such as lid apertures, locks and towing brackets, please refer to the separate accessories sheet for 4-wheeled containers



SULO MGB Australia Pty Ltd
123 Wisemans Ferry Road
Somersby NSW 2250

Australia

Tel: +61 (0) 2 - 4348 8188
Fax: +61 (0) 2 - 4348 8128
Internet: www.sulo.com.au
E-mail: info@sulo.com.au

SULO – Queensland Office
11 Argon Street
Sumner Park QLD 4074

Australia

Tel: +61 (0) 7 - 3725 5000
Fax: +61 (0) 7 - 3725 5099

Quality

- Certified according to DIN EN 840 and RAL GZ 951/1
- Constant quality control through manufacturers laboratory as well as independent institutes

Dimensions - Weights - Standards

■ Nominal volume:	1100 litres
■ Net weight:	approx. 65 kg
■ Max. load:	440 kg
■ Permitted total weight:	510 kg

Measurements to be used as a guide only - variations will occur

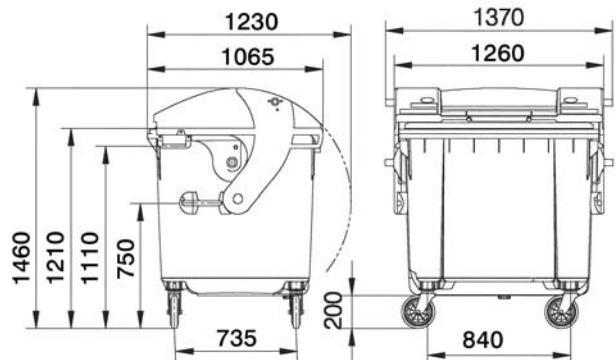

Note: Certification and Quality Marks depicted in this brochure are registered to SULO Umwelttechnik GmbH & Co. KG

Colours

- Standard colours: green, blue, yellow
- Special colours are available on request*
- All additives are cadmium free and environmentally friendly



Imprints and markings

- Manufacturer, year of manufacture, material
- Nominal volume, max. permitted total weight
- EN 840, RAL markings
- Individual markings with imprints, hot-foil printing or adhesive labels available on request*

SULO – Victorian Office
1950 Hume Hwy
Campbellfield VIC 3061

Australia

Tel: +61 (0) 3 - 9357 7320
Fax: +61 (0) 3 - 9357 7340

SULO - New Zealand
PO Box 58 962

Greenmount, Manukau City 2141

New Zealand

Tel: +64 9 273 6870
Fax: +64 9 273 8483